

| SPECIFICATIONS | |
|-----------------|--|
| WEIGHT | 410 LBS (186 KG) |
| ELECTRICAL | UNIVERSAL INPUT, 100V TO 240V VAC, 50/60 Hz POWER CONSUMPTION: 1800W (VA) MAX |
| AIR FEED | 5 CFM/80 PSI OF CLEAN, DRY AIR |
| PASS-THROUGH | UP TO 6 INCHES (152 MM) |
| BAG THICKNESS | 1.09 - 4.0 MIL |
| BAG SIZES | WIDTH: 4 to 16 INCHES (102 TO 406 MM)/ LENGTH: 5.5 to 27 INCHES (140 TO 686 MM) |
| WEIGHT CAPACITY | UP TO 5 LBS (2.3 KG)(WITH LOAD SHELF) |

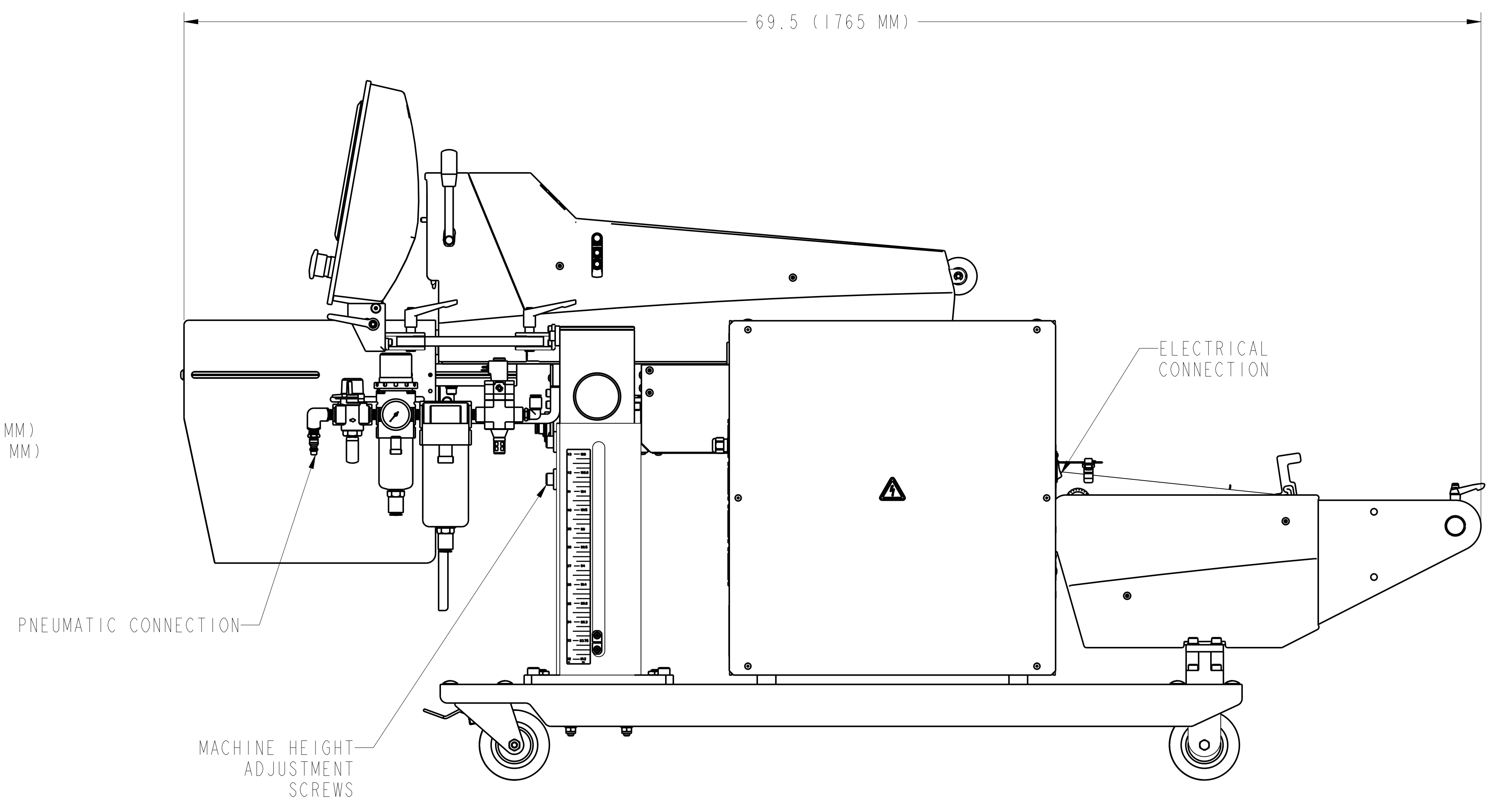
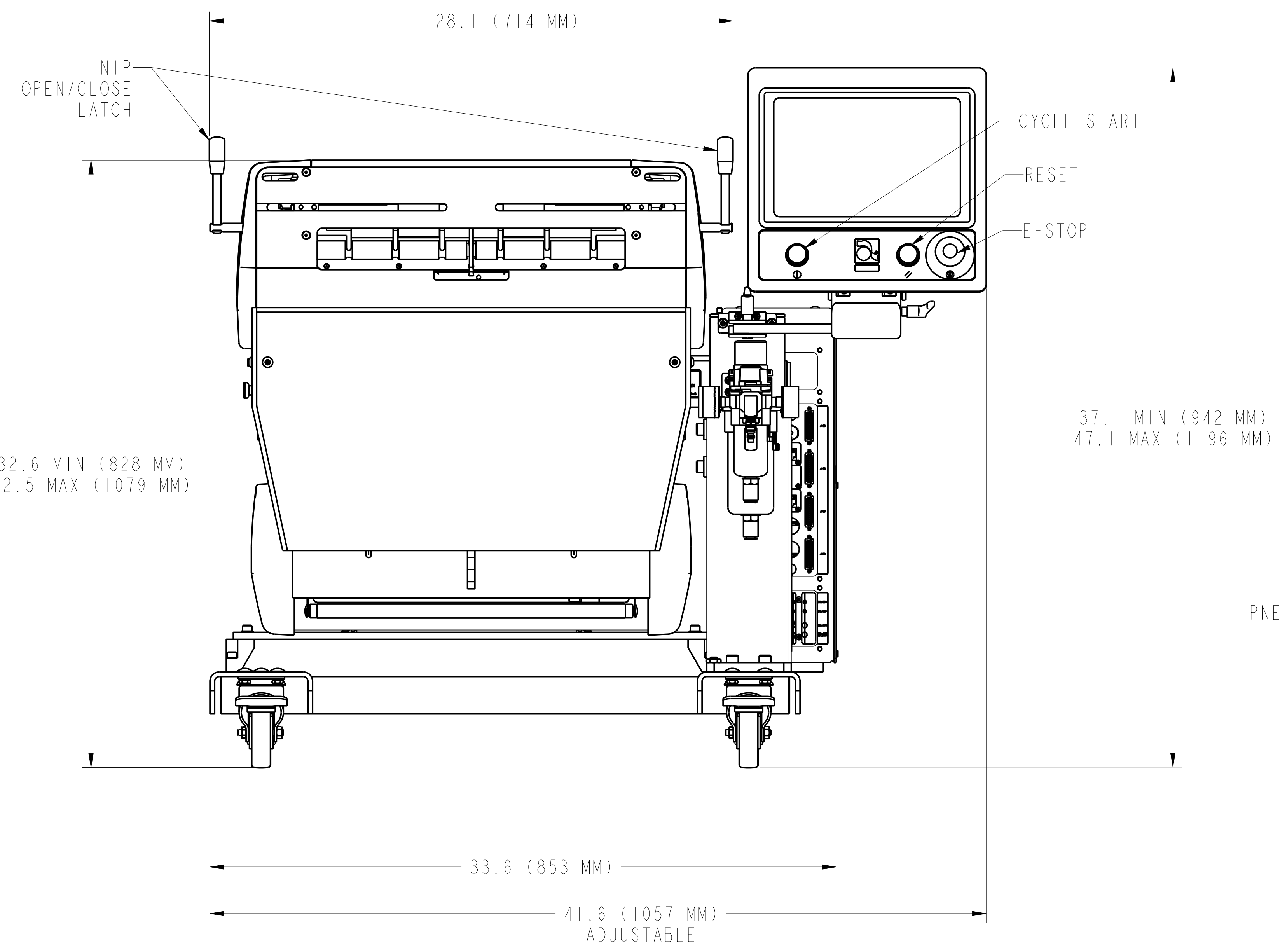
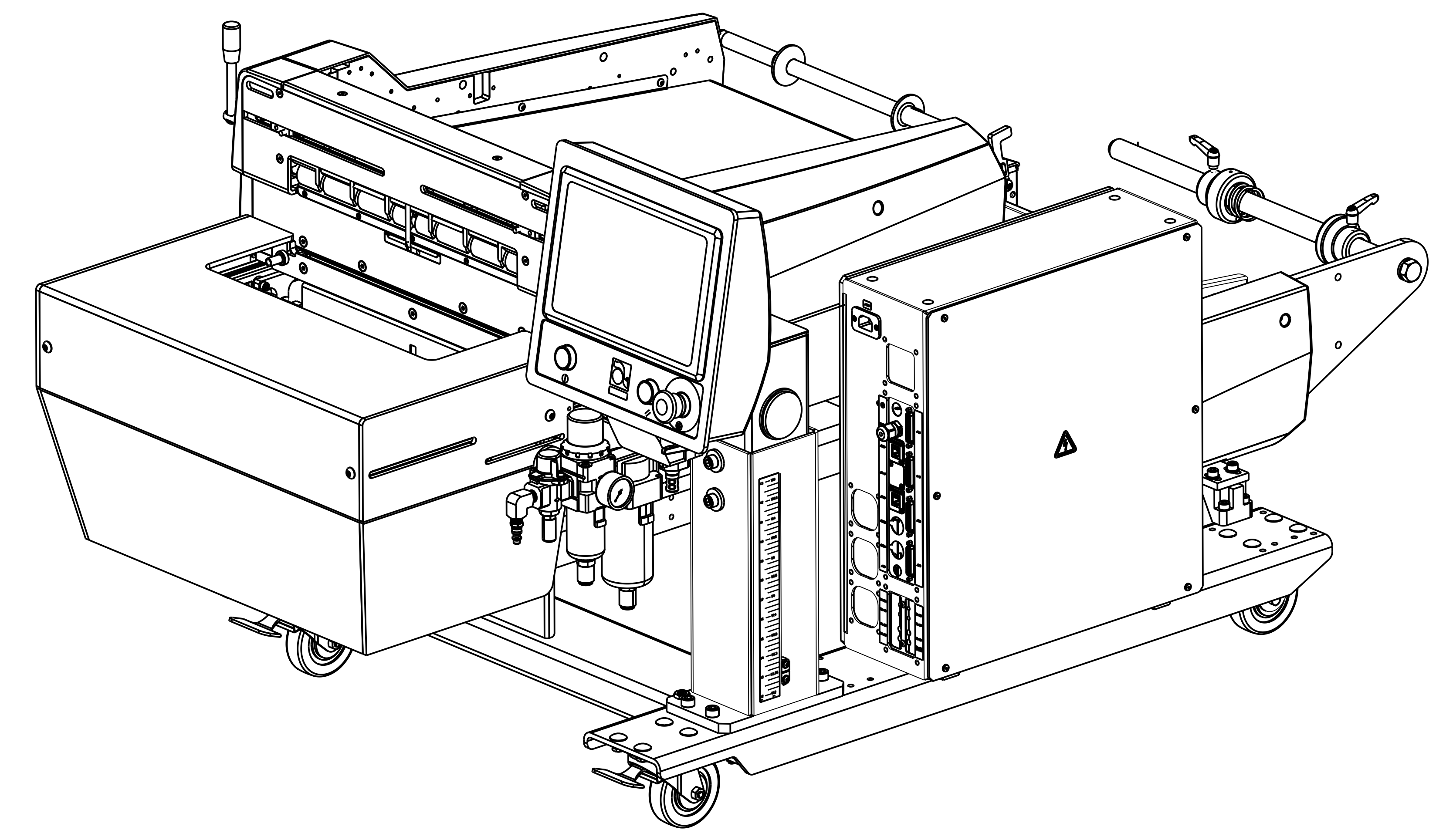
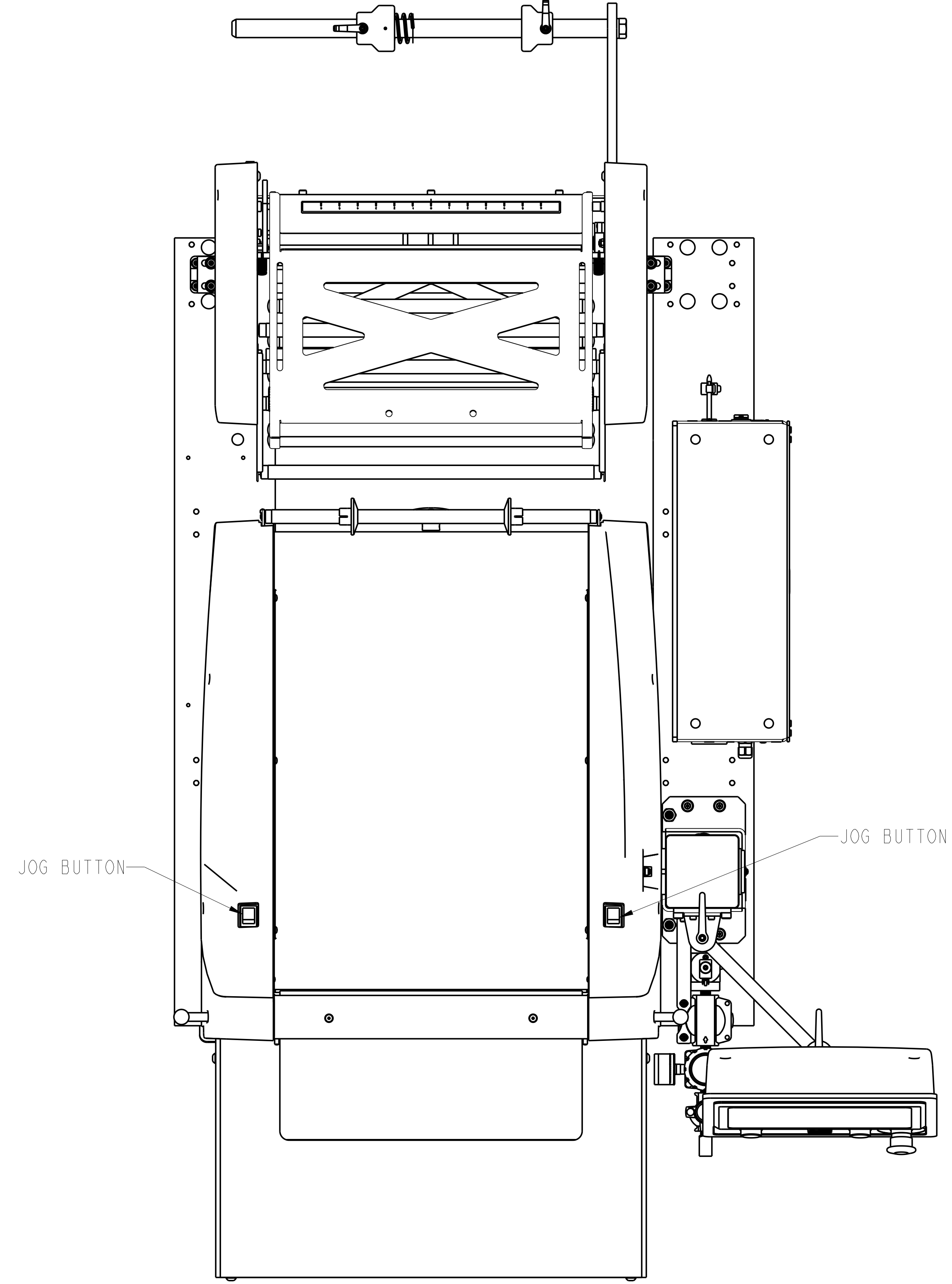

Fabricated & Documented to be RoHS Compliant

| | |
|---|--------------------|
| FINISH | NONE |
| MATERIAL | N/A |
| MACHINING SURFACES TO BE NO GREATER THAN 125 (3.2) ✓ PREFERRED SURFACE FINISH PARTS MUST BE FREE OF BURRS AND SHARP EDGES | |
| TOLERANCES | FRACTIONS DECIMALS |
| 1 PLACE DIMS | ± .1 |
| 2 PLACE DIMS | ± .05 |
| 3 PLACE DIMS | ± .01 |
| ANGLES | ± .1° |

| | | | | |
|-----|-----|---------|------|-------------------|
| REV | BY | DATE | ECN | DESCRIPTION |
| B | AZ | 1-23-20 | | METRIC DIMENSIONS |
| A | DMF | 8-1-19 | 1896 | RELEASED |

Automated PACKAGING SYSTEMS
10175 PHILIPP PARKWAY - STREETSBORO, OH 44221

| | | | | | |
|--------------|-------|----------|--------|-----|-------------|
| DRAWING SIZE | SCALE | DRAWN BY | DATE | REV | DESCRIPTION |
| E | 1/4 | DMF | 8-1-19 | | |

FOOTPRINT: AB600
SHEET 1 OF 1
REV. B
FP263