

TECHNICAL SPECIFICATIONS - BAGGER:
 - WEIGHT: 475 lbs [215kg]
 - ELECTRICAL: 115 VAC; 60 Hz ; 20 A
 - AIR: 5 CFM@60 PSI CLEAN DRY AIR
 - PRODUCT PASS THROUGH: 5 IN [12,7 cm]

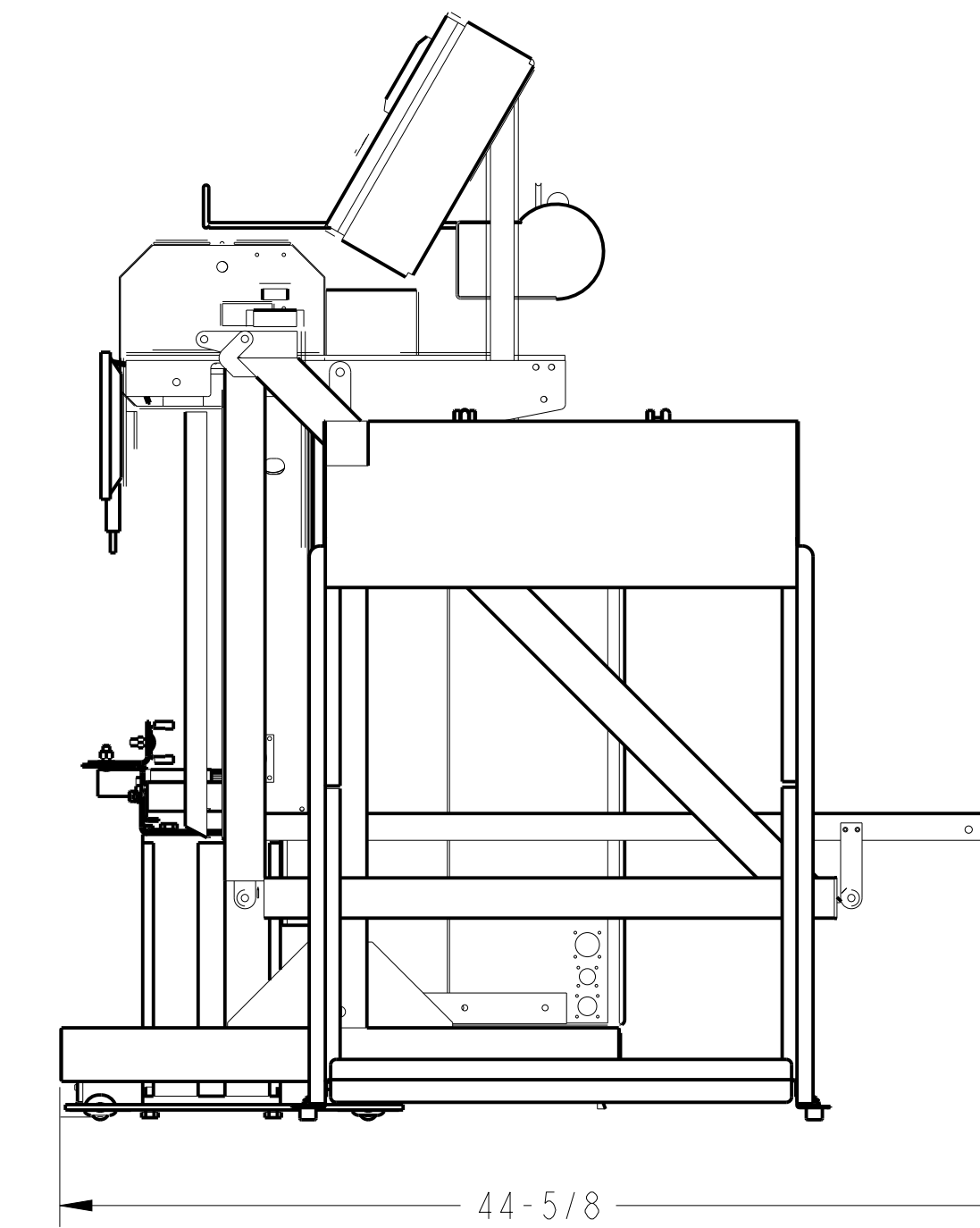
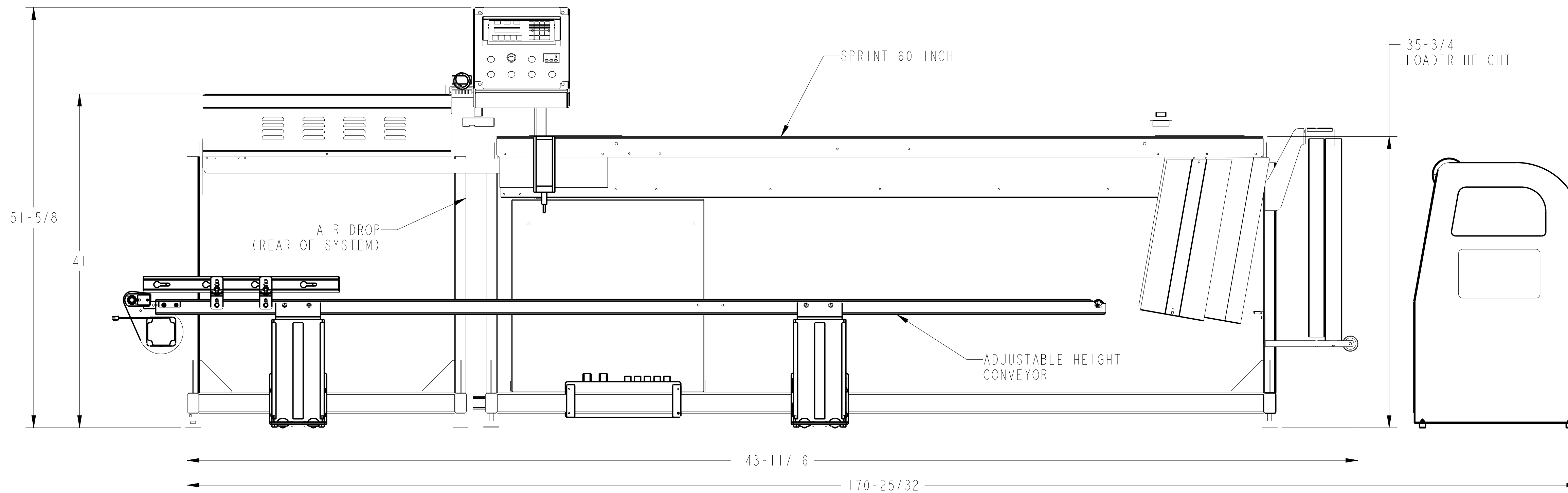
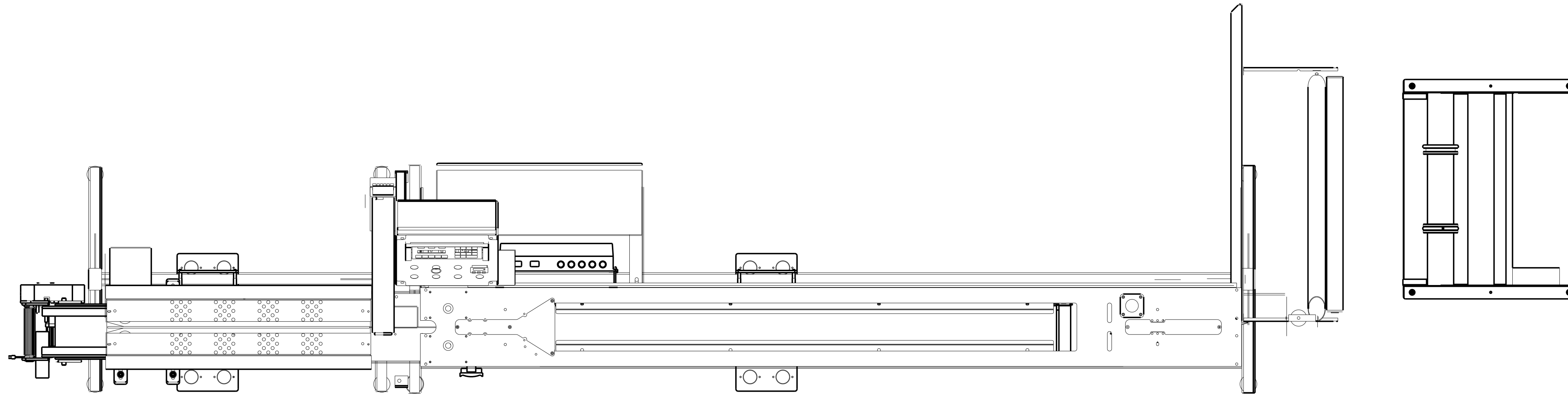

Fabricated & Documented
to be RoHS Compliant

FINISH	NONE
MATERIAL	SPRINT SYSTEM
MACHINE SURFACES TO BE NO GREATER THAN 125 13.21 ✓ UNLESS OTHERWISE NOTED PART MUST BE FREE OF BURRS AND SHARP EDGES	
TOLERANCE	INCHES mm
1 PLACE DIMS	±.01 ±.25
2 PLACE DIMS	±.02 ±.51
3 PLACE DIMS	±.005 ±.10
ANGLES	± 1/2°
NOTICE: THIS DOCUMENT CONTAINS PROPRIETARY INFORMATION AND IT SHALL NOT BE USED OR REPRODUCED OR ITS CONTENT DISCLOSED, IN WHOLE OR PART, WITHOUT THE PRIOR WRITTEN CONSENT OF AUTOMATED PACKAGING SYSTEMS INC.	
INCH [MM]	THIRD ANGLE PROJECTION

A				CW				6-26-17				1006				RELEASED			
REV	BY	DATE	ECN	DESCRIPTION															
 Automated PACKAGING SYSTEMS 10175 PHILIPP PARKWAY · STREETSBORO, OH 44241																			
DRAWING SIZE	SCALE	DRAWN BY	BOM REFERENCE NUMBER																
D	1/8	NAME: DMF																	
		DATE: 3-29-17																	
TITLE: SPRINT, 60 INCH W/SUPPORT CONVEYOR														DRAWING NO. SHEET 1 OF 1					
														REV					
														FP235					