

8191C Custom Blow Off Conveyor

Description

The Cryovac® 8191 C custom Blow-Off conveyor is designed with a high volume 5 HP blower to remove the excess water from packages emerging from a hot water shrink tunnel or chill tunnel. The process of removing the excess water can help prevent damage to corrugate boxes during shipping. The 8191C is custom built to meet customer needs and is available in various conveyor widths, lengths and elevations.

Key Benefits



OPERATIONAL
EFFICIENCY

- Eliminate shipping damage by removal of water from products
- Designed for use in USDA inspected plants
- Stainless Steel Construction



FOOD
SAFETY

- Optimal hygiene and safety with removal of water from products



SHELF LIFE
EXTENSION

- Superior product appearance with Cryovac® shrink bags with skin-tight shrink



8191C Custom Blow Off Conveyor

Technical data

- | | |
|---|---|
| <p>Machine Dimensions
Machine Dimensions:
Entry Elevation: 33" (839 mm) – 46" (1168 mm) +/- 3" (76 mm)
Specified when ordered
Exit Elevation: 40" (1016 mm) – 56" (1422 mm) +/- 3" (76 mm)
Specified when ordered</p> <p>Length: 78" (1981 mm) Minimum</p> | <p>Variable Speed
Belt Description: 24" (609 mm) Wide, KVP Fluid Flo
Speed: Variable from 20 FPM to 85 FPM</p> |
| <p>Weight:
Weight:

Construction: Stainless Steel</p> | <p>Electrical Voltage
Electrical: 460 VAC, 3 Phase, 60 HZ, 15 AMP</p> |
| <p>Product dimensions
Product Size: Minimum 8" (203 mm) L x 6" (152 mm) W x 2" (50 mm) H
Maximum 33" (838 mm) L x 21" (533 mm) W x 12" (304 mm) H
Options: Available with or without water recovery system</p> | <p>Utilities
Blower Requirements: 5HP
(Supplied on the unit) 208/230/460 VAC
15.4/13.6/6.3 AMP
3 Phase, 60HZ</p> |

Line layout example

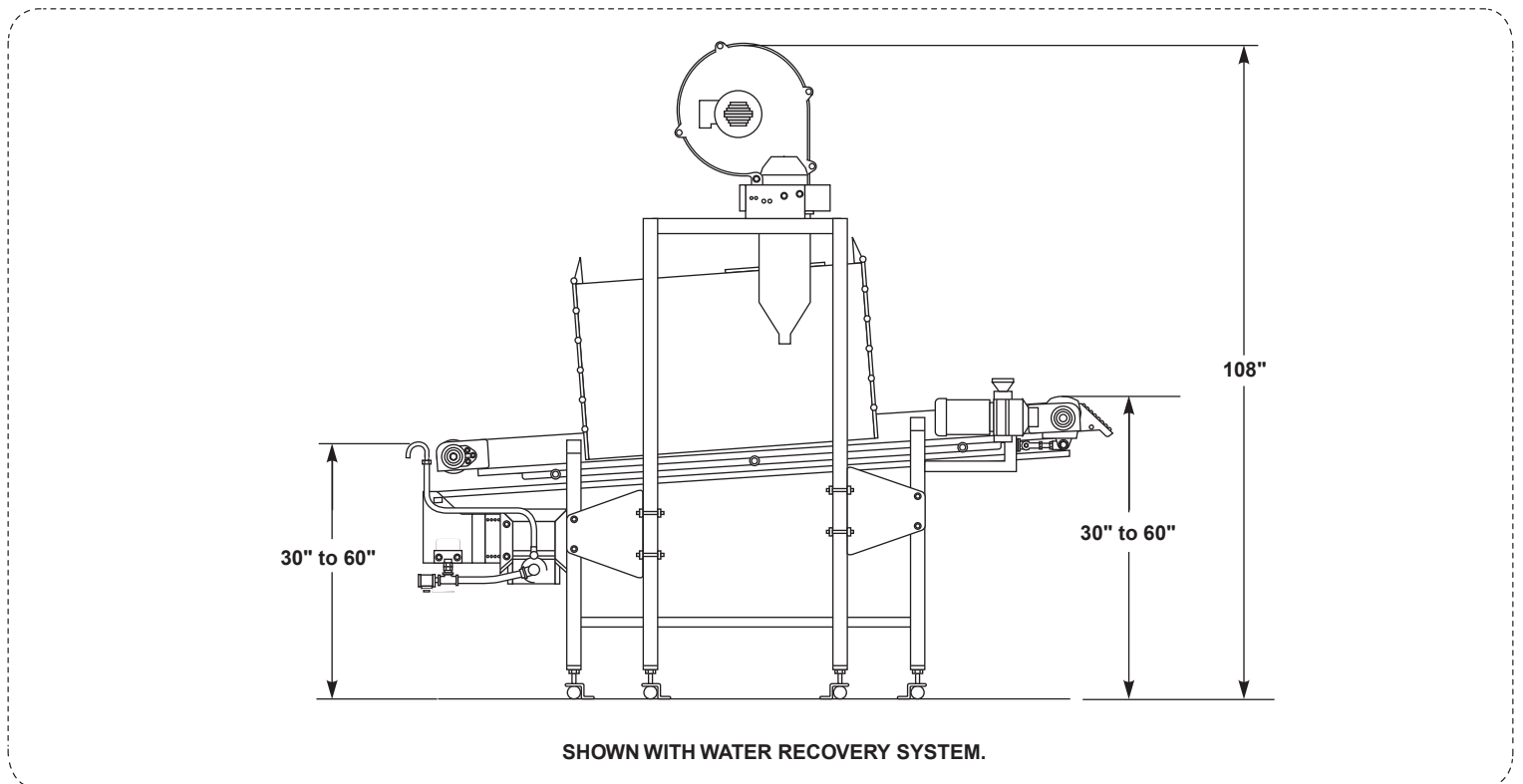

Contact

foodcare.na@sealedair.com