

SPECIFICATIONS	
WEIGHT	450 LBS (204.1 KG)
ELECTRICAL	UNIVERSAL INPUT, 100V TO 240V VAC, 50/60 Hz POWER CONSUMPTION: 1800W (VA) MAX
AIR FEED	5 CFM/80 PSI OF CLEAN, DRY AIR
PASS-THROUGH	UP TO 6 INCHES (152 MM)
BAG THICKNESS	1.09 - 4.0 MIL
BAG SIZES	WIDTH: 4 to 16 INCHES (102 TO 406 MM) / LENGTH: 5.5 to 27 INCHES (140 TO 686 MM)
WEIGHT CAPACITY	UP TO 5 LBS (WITH LOAD SHELF)

PRINTER SPECIFICATIONS	
WEIGHT	68 LBS (31 KG)
ELECTRICAL	100-240V, 50/60 Hz, 2.4 KW
AIR FEED	SUPPLIED FROM BAGGER
LABEL SIZE	UP TO 4 INCHES (102 MM) WIDE, 20 INCHES (508 MM) LONG

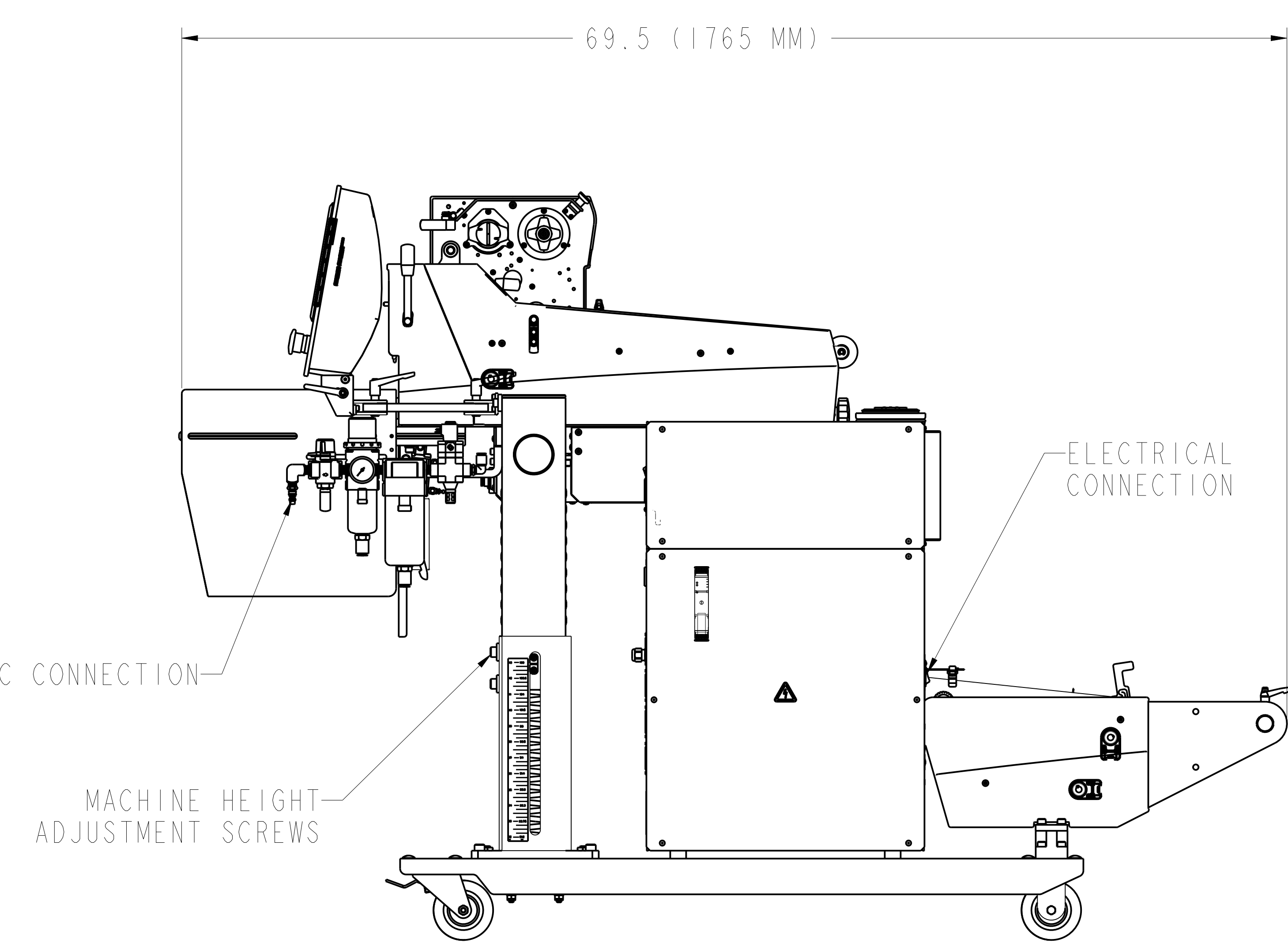
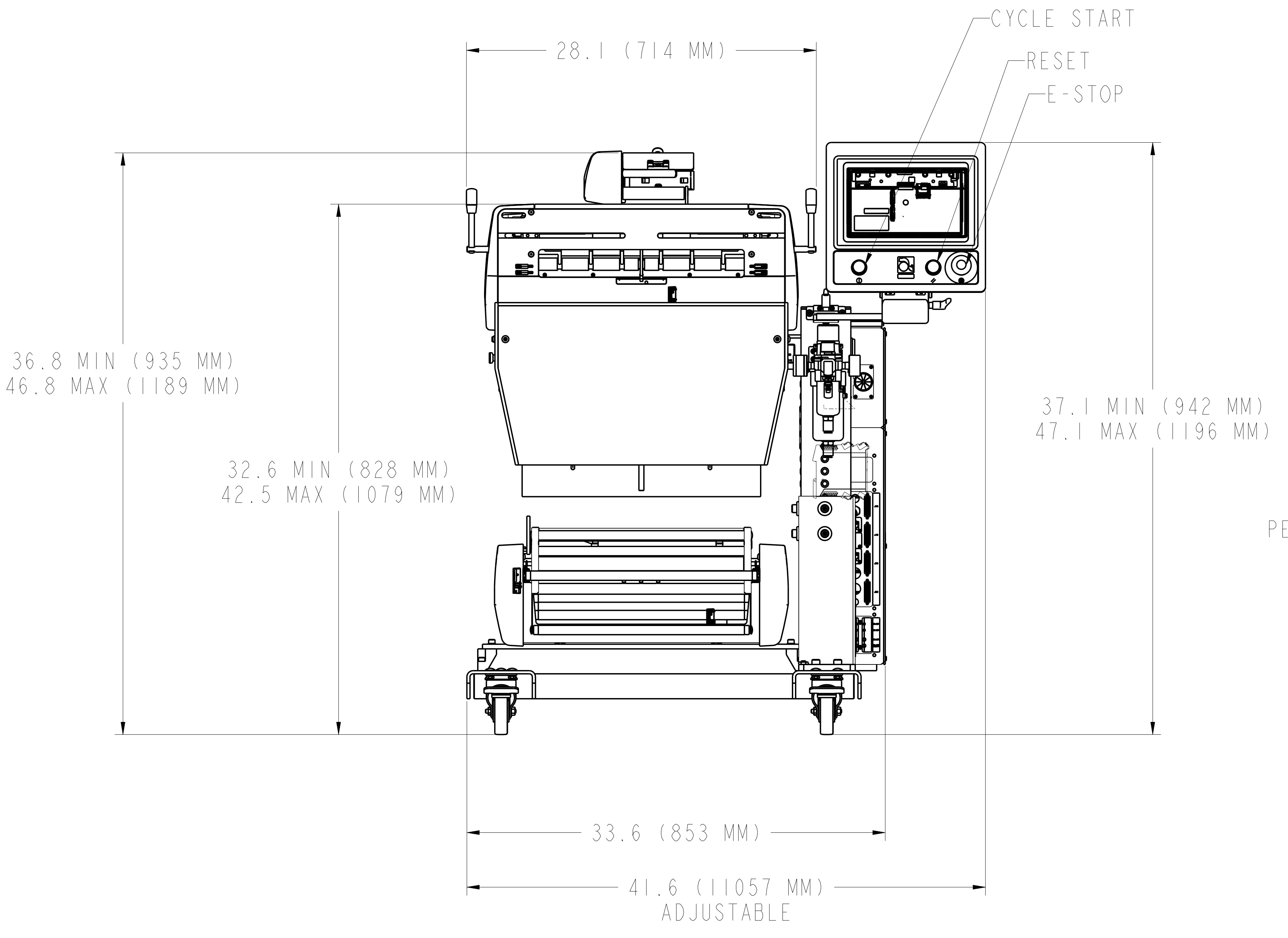
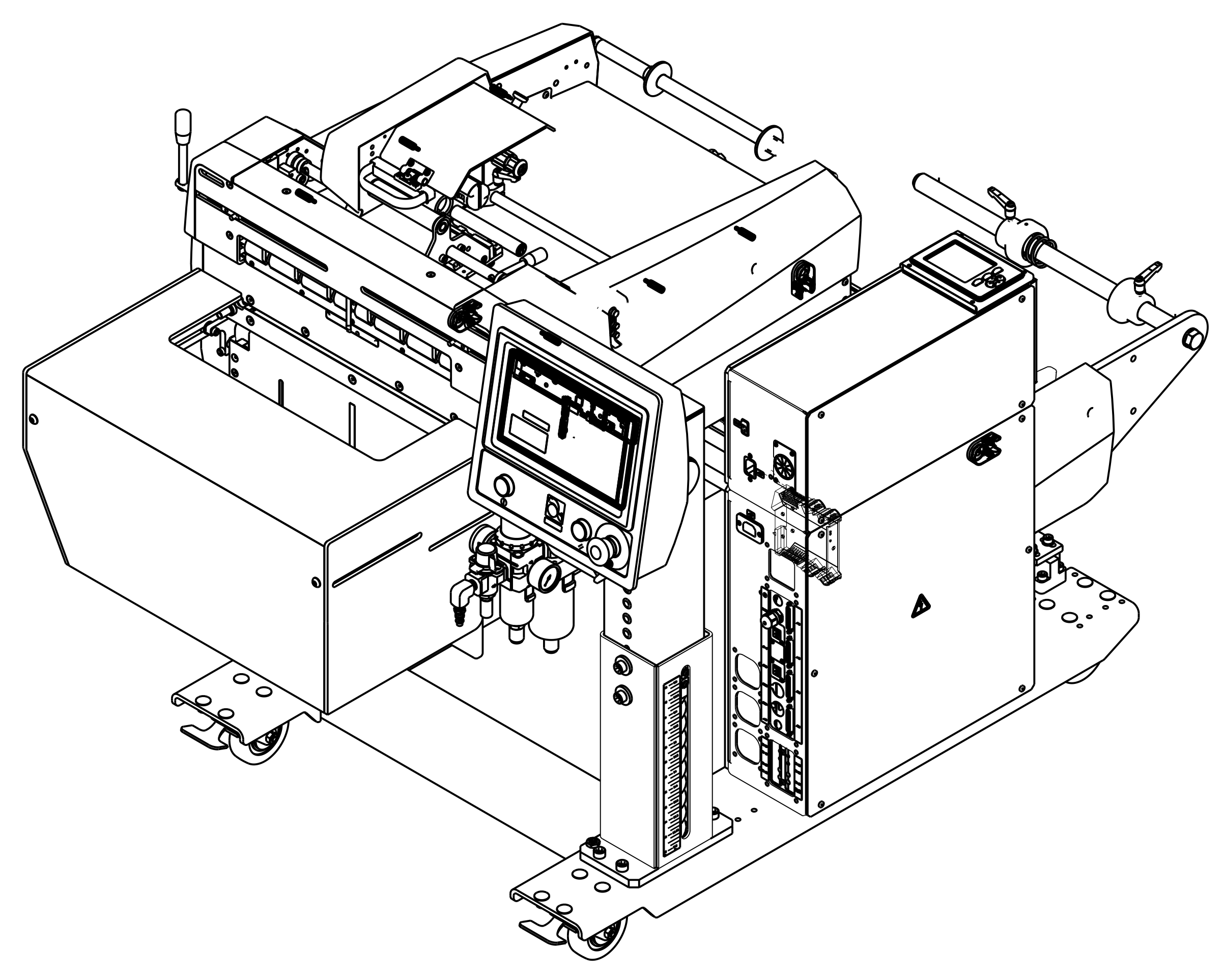
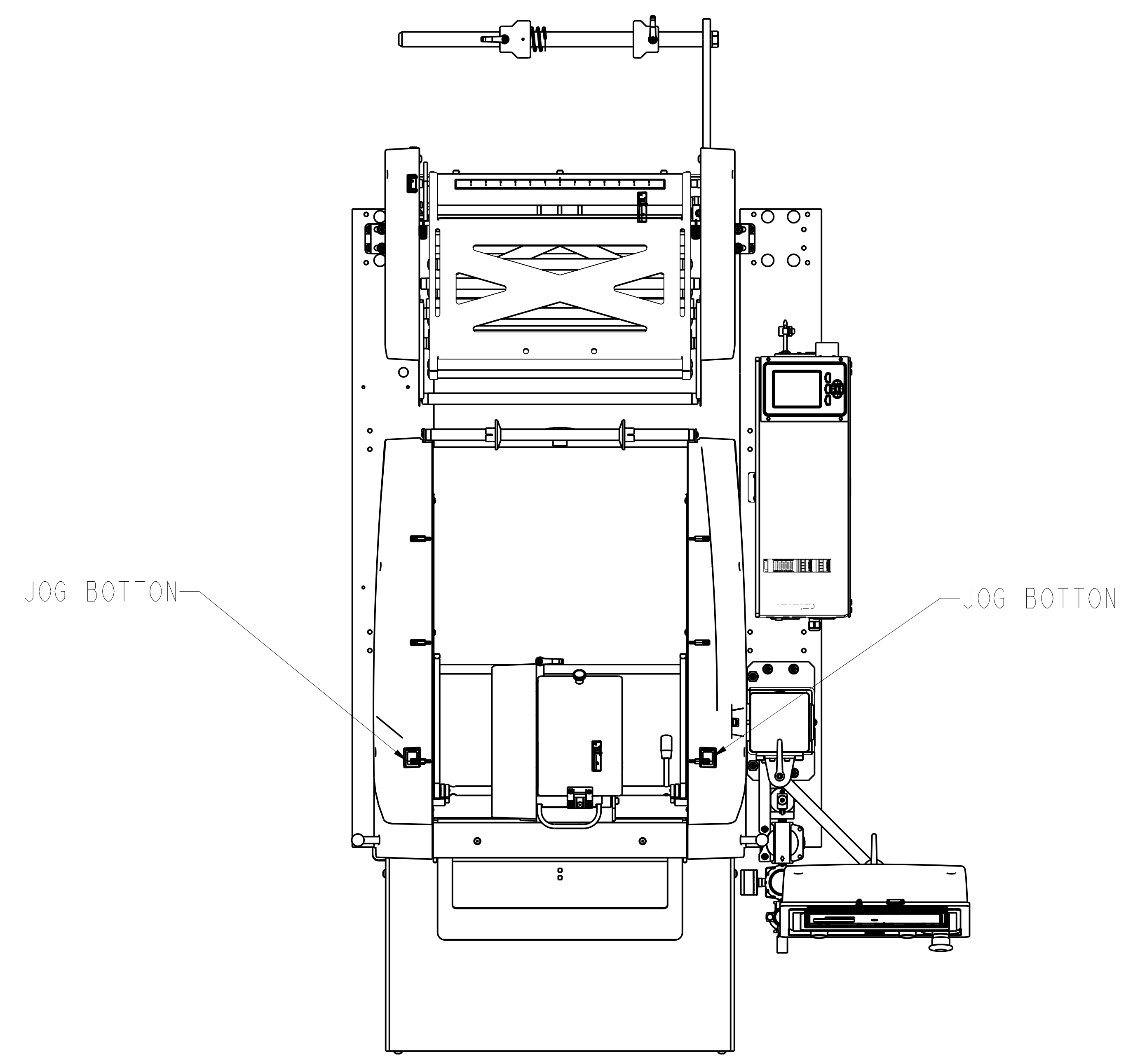

Fabricated & Documented to be RoHS Compliant

FINISH	NONE															
MATERIAL	N/A															
REVISIONS	<table border="1"> <thead> <tr> <th>REV</th> <th>BY</th> <th>DATE</th> <th>ECN</th> <th>DESCRIPTION</th> </tr> </thead> <tbody> <tr> <td>B</td> <td>AZ</td> <td>1-23-20</td> <td></td> <td>METRIC DIMENSIONS</td> </tr> <tr> <td>A</td> <td>DMF</td> <td>4-1-19</td> <td>1896</td> <td>RELEASED</td> </tr> </tbody> </table>	REV	BY	DATE	ECN	DESCRIPTION	B	AZ	1-23-20		METRIC DIMENSIONS	A	DMF	4-1-19	1896	RELEASED
REV	BY	DATE	ECN	DESCRIPTION												
B	AZ	1-23-20		METRIC DIMENSIONS												
A	DMF	4-1-19	1896	RELEASED												
<table border="1"> <thead> <tr> <th>DRIVING SIZE</th> <th>SCALE</th> <th>DRAWN BY</th> <th>DATE</th> <th>REV</th> <th>DESCRIPTION</th> </tr> </thead> <tbody> <tr> <td>E</td> <td>1/4</td> <td>DMF</td> <td>4-1-19</td> <td></td> <td></td> </tr> </tbody> </table>	DRIVING SIZE	SCALE	DRAWN BY	DATE	REV	DESCRIPTION	E	1/4	DMF	4-1-19			<p>Automated PACKAGING SYSTEMS 10175 PHILIPP PARKWAY - STREETSBORO, OH 44224</p> <p>10175 PHILIPP PARKWAY - STREETSBORO, OH 44224</p> <p>10175 PHILIPP PARKWAY - STREETSBORO, OH 44224</p>			
DRIVING SIZE	SCALE	DRAWN BY	DATE	REV	DESCRIPTION											
E	1/4	DMF	4-1-19													
<p>NOTE: THIS DOCUMENT CONTAINS PROPRIETARY INFORMATION AND IS INTENDED FOR USE BY THE CUSTOMER. IT IS NOT TO BE REPRODUCED OR TRANSMITTED IN ANY FORM OR BY ANY MEANS WITHOUT THE WRITTEN CONSENT OF AUTOMATED PACKAGING SYSTEMS INC.</p>	<p>THIRD ANGLE PROJECTION</p>															
<p>INCH (MM)</p>	<p>FOOTPRINT, AB650</p>															
<p>SHEET 1 OF 1</p>	<p>AB650</p>															